

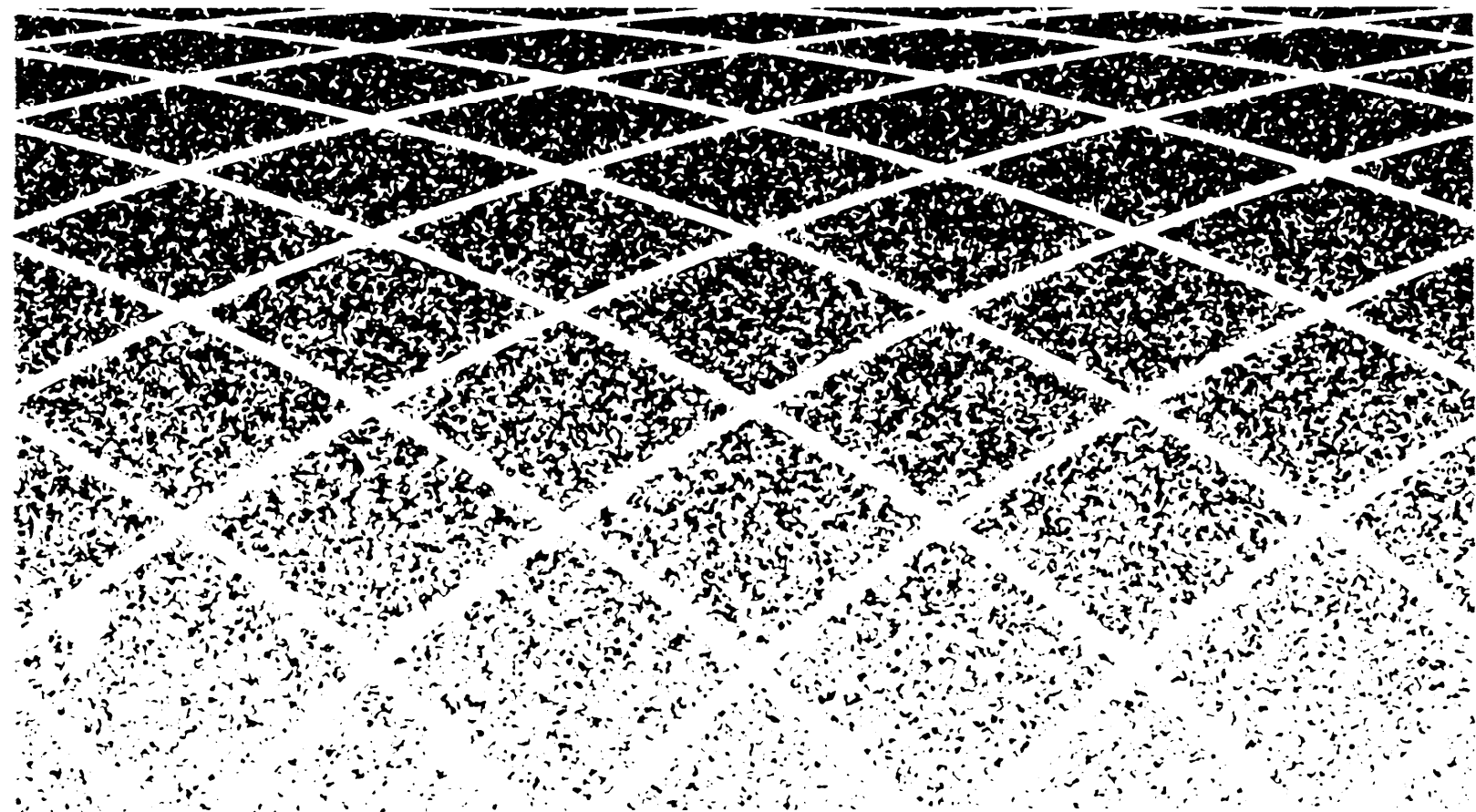

PARTNER[®] Plus
Communications System
Release 3

Installation



**Copyright © 1992 AT&T
All Rights Reserved
Printed in U.S.A.**

**AT&T 518-455-213
Issue 1
June 1992**

Notice

Every effort was made to ensure that the information in this book was complete and accurate at the time of printing. However, information is subject to change.

Federal Communications Commission (FCC) Interference Notice

This equipment has been tested and found to comply with the limits of a Class A digital device, pursuant to Part 15 of FCC rules. These limits are designed to provide reasonable protection against harmful interference when the equipment is operated in a commercial environment. This equipment generates, uses, and can radiate radio frequency energy and, if not installed and used in accordance with the instruction manual, may cause harmful interference to radio communications. Operation of this equipment in a residential area is likely to cause harmful interference, in which case the user will have to correct the interference at his or her own expense. For additional FCC information, see Appendix C of the PARTNER Plus Communications System Programming and Use guide.

Canadian Emissions Requirements

This digital apparatus does not exceed the Class A limits for radio noise emissions from digital apparatus set out in the Radio Interference Regulations of the Canadian Department of Communications.

Le present appareil numerique n'emet pas de bruits radioelectriques depassant les limites applicables aux appareils numeriques de la classe A prescrites dans le Reglement sur le brouillage radioelectrique edicte par le ministere des Communications du Canada.

Trademarks

MLS-34D, MLS-18D, MLS-12D, MLS-12, MLS-6, Call Assistant, and SYSTIMAX are trademarks of AT&T. PARTNER, Magic on Hold, MERLIN, and PagePac are registered trademarks of AT&T.

Warranty

AT&T provides a limited warranty to this product. See Appendix B of the *PARTNER Plus Communications System Programming and Use* guide.

Ordering Information

The order number for this book is 518-455-213. To order additional books, call 1 800 432-6600 in the U.S. and 1 800 255-1242 in Canada. For more information on how to order this and other system reference materials, see "Reference Materials" in the *PARTNER Plus Communications System Programming and Use* guide. For information on ordering replacement parts, accessories, and other compatible equipment, refer to "Product Ordering Information" in Appendix B of that guide.

Support Telephone Numbers

In the continental U.S., AT&T provides a toll-free customer helpline 24 hours a day. Call the AT&T Helpline at **1 800 628-2888** if you need assistance when installing your system.

Outside the continental U.S., contact your local AT&T Authorized Dealer.

Contents

Important Safety Instructions	ii
Overview	1
An Example System Setup	2
Required Parts	4
Installation Guidelines	5
■ Telephones and Devices	5
■ Combination Extensions	6
Using A Direct Connection	6
Using a Bridging Adapter	6
Installation Procedures	7
■ Installing the Control Unit and Modules	7
■ Connecting Lines and Extensions	9
■ Connecting Caller ID Display Units	11
■ Assembling System Phones	12
Desk Mounting	12
Wall Mounting	13
■ Connecting and Testing Telephones	14
■ Connecting Paging, Music-On-Hold, and Call Reporting (SMDR) Devices	15
■ Connecting Intercom Autodialers	16
Equipment Upgrades	17
■ Adding New Modules	17
■ Replacing System Modules	18
Specifications	20

Important Safety Instructions

Always follow these basic safety precautions when using the system:

1. Read and understand all instructions.
2. Follow all warnings and instructions marked on the product.
3. Never spill liquid on the product or drop objects into the ventilation slots and openings. Doing so may result in serious damage to the components.
4. Repair or service must be performed by a qualified repair person.
5. The product is provided with a three-wire grounding type plug. This is a safety feature. DO NOT defeat the safety purpose of the grounding type plug. DO NOT staple or otherwise attach the AC power supply cord to building surfaces.
6. DO NOT use the product near water or in a wet or damp place (such as a wet basement).



CAUTION

DO NOT block or cover the ventilation slots and openings. They prevent the product from overheating. DO NOT place the product in a separate enclosure unless proper ventilation is provided.

Additional Safety Instructions for Installation Personnel

1. DO NOT install telephone wiring during a lightning storm.
2. DO NOT install telephone jacks in a wet location unless the jack is specifically designed for wet locations.
3. Never touch uninsulated telephone wires or terminals, unless the telephone line has been disconnected at the network interface.
4. Use caution when installing or modifying telephone lines.
5. The control unit must be securely wall mounted.



CAUTION:

If any wiring from the extension jacks leaves the building premises, you must install AT&T IROB protectors (see "Requirements for Out-of-Building Extensions" on page 21).



CAUTION:

Use only AT&T-manufactured PARTNER modules in the PARTNER Plus Communications System.



CAUTION:

Environmental and electrical conditions must meet the specifications as listed on pages 20 and 21.

SAVE THESE INSTRUCTIONS

Installation

Overview

This guide explains how to install the system. It begins with an example system setup, then follows with an illustration of the components you need to install the system and general guidelines to consider before installation. Next, it provides step-by-step instructions for connecting and testing the components for initial installation and upgrades. Finally, it ends with important system specifications and requirements.

If your company already has modular jacks for all outside lines and extensions, you may be able to use the existing wiring to install the system hardware and connect telephones to the system yourself. To have an AT&T service technician install and customize your system or change existing wiring, call 1 800 247-7000 (in the continental U.S. only) or call your AT&T Authorized Dealer.

After installation, refer to the *PARTNER Plus Communications System Programming and Use* guide for programming instructions.

An Example System Setup

The next page shows a control unit with two 206 modules and two 400 modules, giving the system a capacity of 12 outside lines and 12 extensions. Although your system may differ, this example will give you an idea of the types of equipment you can connect to it. In the example, system phones and industry-standard devices are connected to nine extensions. The circled numbers in the figure refer to the following list, which gives a brief description of the system's hardware components.

Control Unit

The control unit consists of these components:

- ① **Backplane.** The backplane channels power to the system and connects the system modules.
- ②A **206 Modules.** Each 206 module has jacks for two lines and six extensions.
- ②B **400 Modules.** Each 400 module provides four line jacks but no extensions. *Notice that the 400 modules are installed to the right of the 206 modules.*
- ③ **Processor Module.** The processor module contains the software that provides the system's features. It also has PAGE, SMDR, and MUSIC ON HOLD jacks.
- ④ **PAGE Jack.** A loudspeaker paging system plugs directly into this modular jack. The system is compatible with any AT&T paging system, including the AT&T PagePac6® shown here.

If you use equipment that rebroadcasts music or other copyrighted materials, you may be required to obtain a license from a third party such as ASCAP or BMI. Or you can purchase a Magic On Hold system from AT&T, which does not require you to obtain such a license.
- ⑤ **SMDR Jack.** A call reporting (or SMDR—Station Message Detail Recording) device connects directly to this jack. AT&T's Call Accounting Terminal serial printer and box are shown here.
- ⑥ **MUSIC ON HOLD Jack.** AT&T's Magic on Hold® is connected to this jack to provide customized music and messages for callers on hold. Other types of audio equipment (including a CD player, cassette player, or stereo receiver) can be connected using an audio cord with an RCA phono plug (not supplied).
- ⑦ **Line Jacks.** The top two jacks on each 206 module, and all four jacks on each 400 module, connect to outside telephone lines.
- ⑧ **Extension Jacks.** The bottom six jacks on each 206 module connect inside wiring for telephones and other telecommunications equipment.
- ⑨ **Network Interface Jacks.** These jacks provide access to telephone lines from the local telephone company. Each outside line is connected to the system by plugging one end of the line cord into one of these jacks, and the other end into a line jack on a 206 or 400 module.

Extensions

Various devices—including system phones and industry-standard devices—can be connected to the modular wall jacks. The modular wall jacks connect to the extension jacks in the control unit by way of the building's inside wiring.

- ⑩ **Extension 10:** These devices are connected:
 - **MLS-34D Display Phone.** Typically, the receptionist on programming extension 10 has an MLS-34D display phone like the one shown here. The display shows the time, dialed numbers, the duration of calls, and programming messages.
An MLS-34D, MLS-18D, or MLS-12D is required for system programming at extension 10 or 11, or both. Use an MLS-18D only if there are no MLS-34D phones in the system. Similarly, use an MLS-12D only if there are no MLS-34D or MLS-18D phones in the system.
 - **Call Assistant™ Intercom Autodialer.** An Intercom Autodialer is connected to the phone, for dialing extensions and transferring calls to them with one touch and for seeing which extensions are busy.
 - **Standard Touch-Tone Phone.** During a power failure, the MLS-34D phone on extension 10 will not work, but the receptionist can use the standard phone to place and receive calls on line 1.
- ⑪ **Extension 11: MLS-34D Display Phone.** Another MLS-34D is connected to programming extension 11. This means you can program the system from this extension while the receptionist at extension 10 is free to handle calls.
- ⑫ **Extension 12: MLS-18D Phone and Answering Machine.** An MLS-18D phone and an answering machine are connected to this extension.
- ⑬ **Extension 13: Standard Phone.** A standard phone (such as you might have in your home) is connected directly to the extension jack.
- ⑭ **Extension 14: Doorphone.** A doorphone is installed at the building entrance. When someone at the entrance presses the button on the doorphone, the designated extensions in the office ring automatically. (Any number of extensions can be designated as doorphone alert extensions.)
- ⑮ **Extension 15: Bell.** A loud bell is connected directly to this extension jack. Any line programmed to ring on extension 15 activates the loud bell—to alert users of an incoming call in a large area, such as a warehouse.
- ⑯ **Extension 16: MLS-12D Display Phone.** This display phone can handle 10 outside lines.
- ⑰ **Extension 17: Fax Machine and Standard Phone.** A fax machine and standard phone share this extension. This lets you have the use of another phone when the fax machine is idle. (You can use a system phone at another extension to monitor fax machine activity—see "Fax Management Feature" of "Using Fax Machines" in Chapter 4 of the *PARTNER Plus Communications System Programming and Use* guide.)
- ⑱ **Extension 18: MLC-6 Cordless Phone.** An AT&T MLC-6 cordless phone is connected to this extension. It works like the corded MLS-6 system phone.

CONTROL UNIT

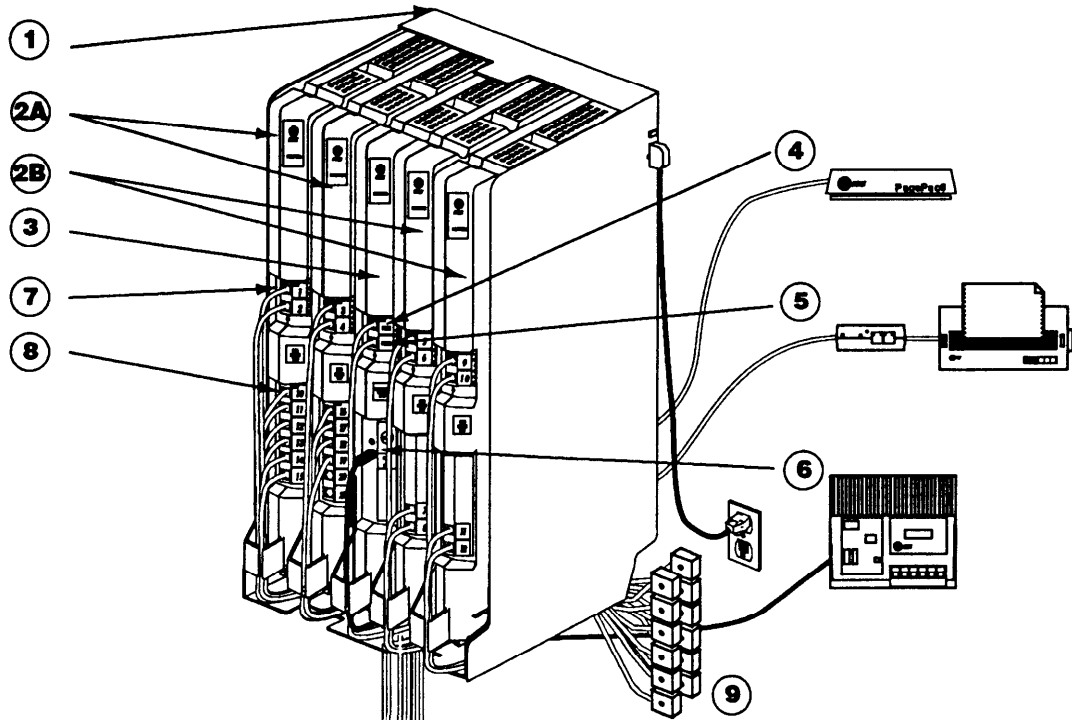

EXTENSIONS

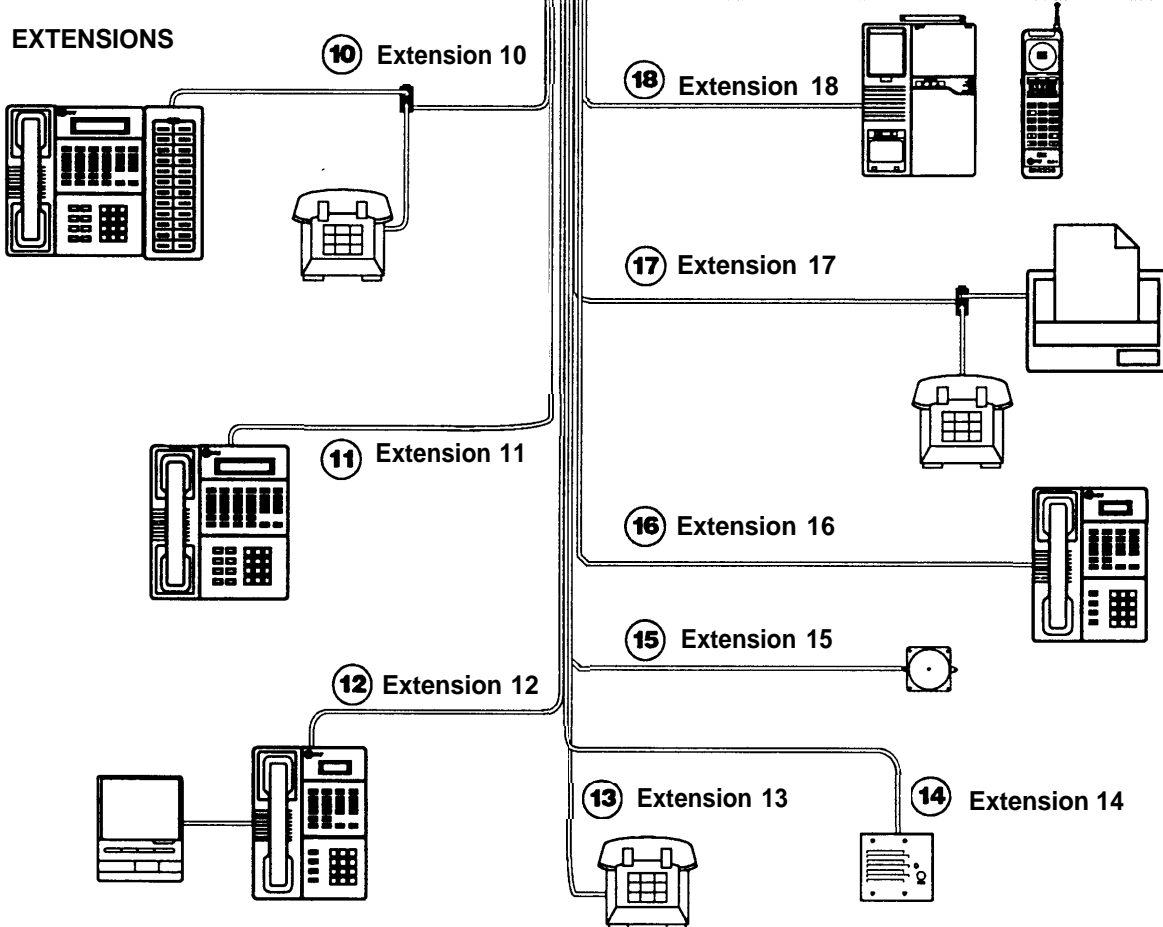

Required Parts

You will have up to three types of system component packages; Figure 1 shows the contents of each package in the area marked by a dashed line. Check your packages to be sure you have the parts shown here (if not, call the appropriate support telephone number as instructed on the inside front cover).

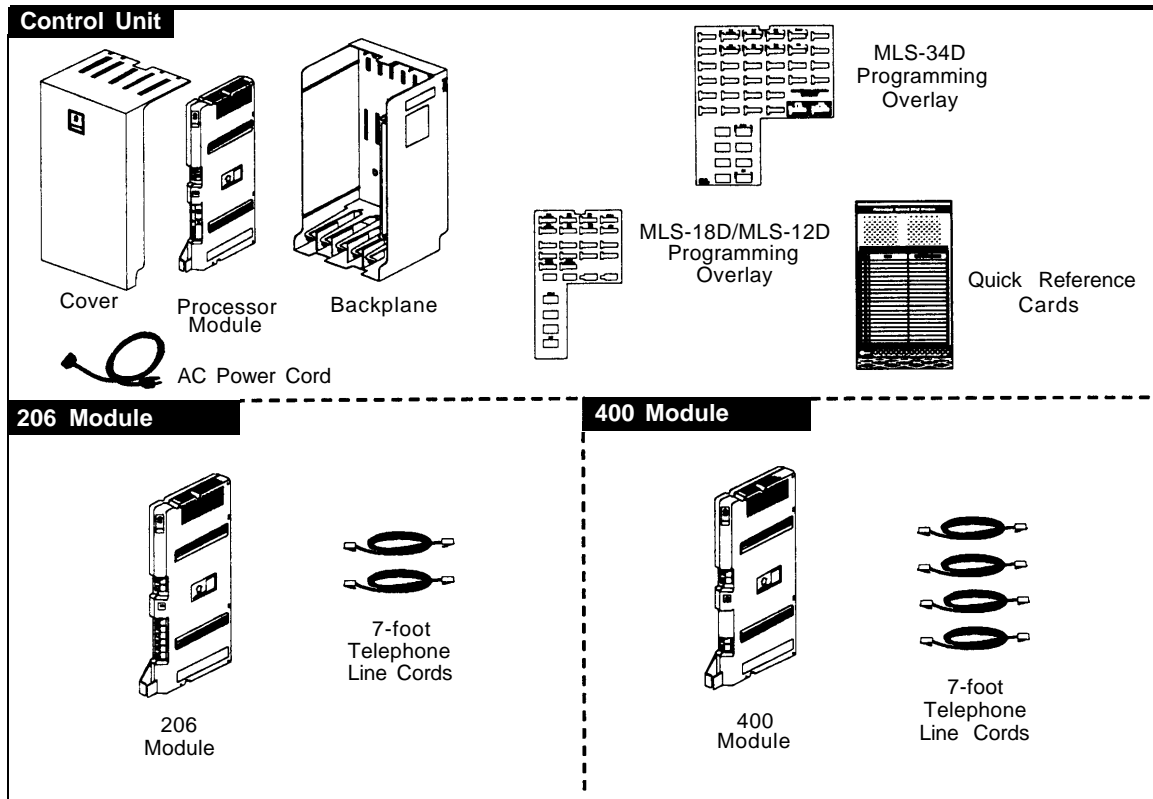

Figure 1. Required Parts

You will need to obtain four #12 screws of the appropriate type for the wall and weight of the control unit (a control unit with four 206 modules and a processor module weighs approximately 27.5 pounds or 12.3 kilograms).

In addition, if you need modular telephone cords for connecting the extension jacks on the control unit to the modular connecting blocks for extensions in the equipment room, short telephone cords for wall mounting MLS-model phones, or a 355A/355AF adapter and D8W telephone cord for connecting a call reporting device, order them before installation. Refer to "Product Ordering Information" in Appendix B of the *PARTNER Plus Communications System Programming and Use* guide for ordering instructions.

NOTE:

A system display phone—either an MLS-34D, MLS-18D, or MLS-12D—is *required* for system programming at extension 10 and/or 11. (Make sure that the programming phone is as large as the largest phone in the system, because an MLS-12D or MLS-18D *cannot* program an MLS-34D. Similarly, an MLS-12D *cannot* program an MLS-18D.)

Installation Guidelines

Telephones and Devices

You can connect the following telephones and devices to the system:

- **MLS- and MLC-Model System Phones.** System phones require at least two-pair wiring and are compatible with AT&T 4-pair SYSTIMAX™ wiring.
- **Call Assistant Intercom Autodialers with Busy Indication (MLS-CA24).** You can connect an Intercom Autodialer to the system phone at extensions 10 and 11 (maximum two per system). The Intercom Autodialer has its own power supply, which must be plugged into an AC outlet.
- **Industry-Standard Devices.** Industry-standard devices (including standard phones) require one-pair mounting cords; AT&T D2R mounting cords are recommended.
 - **Standard Phones.** Connect standard touch-tone or rotary dial phones to the system for:
 - **Power Failure Operation.** During a power failure, system phones will not work because they require power to operate. However, if you connect standard phones to extensions 10, 16, 22, and 28, users can place and answer outside calls on lines 1, 3, 5, and 7, respectively. You can connect a standard phone either alone or combined with a system phone. (If you combine a standard phone and a system phone on one extension, you may want to turn off the standard phone's ringer during normal use.)
 - **Hotlines.** A hotline extension should be connected to a standard phone, rather than a system telephone, but can ring any type of phone. A hotline phone can also be set up to ring the paging system, so announcements can be made over the loudspeaker. Do not connect a Hotline phone to extension 10, 16, 22, or 28, to keep them available for power failure use.
 - **Auxiliary Equipment.** There are a variety of ways to set up fax machines, modems, and answering machines to work with the system. See Chapter 4 in the *PARTNER Plus Communications System Programming and Use* guide for advice on using this equipment. To connect a telephone and a standard device on the same extension, see "Combination Extensions" on page 6.
- **Doorphones.** You can connect up to two doorphones to the system. Do not connect doorphones to extension 10, 11, 16, 17, 22, 23, 28, or 29.
- **Call Reporting Devices.** You can connect a call reporting device to the SMDR jack on the processor module for recording call activity.
- **In-Range Out-of-Building Protectors.** Installing phones in a different building from the control unit requires AT&T In-Range Out-of-Building (IROB) protectors, to prevent damage due to lightning. (IROBS must be installed by a qualified technician.)

Combination Extensions

You can connect a standard device (such as a standard phone or an answering machine) on an extension by itself, or so that it shares an extension with another piece of equipment (either another standard device or a system phone). An extension with two devices connected to it is called a *combination extension*. You cannot install two system phones on the same extension, and the combined REN (Ringer Equivalence Number) of two devices on one extension cannot exceed 2.0. (The REN for a system phone is 0.0.)

If your system phone has a built-in auxiliary jack, you can connect a standard device directly to the phone, without using a bridging adapter—see “Using A Direct Connection” below. If your system phone does not provide a built-in auxiliary jack or if you want to connect two standard devices together, you must use an AT&T 267F2 bridging adapter to combine the two devices on one extension—see “Using a Bridging Adapter” below.

Using A Direct Connection

Figure 2 shows you how to connect a standard device directly to a system phone, using the phone’s built-in auxiliary jack.

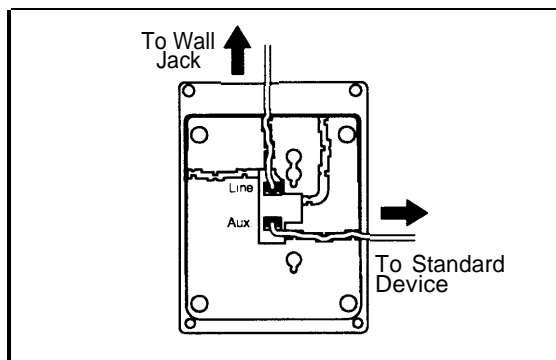

Figure 2. Combination Extension Using Direct Connection

Using a Bridging Adapter

Figure 3 shows you how to connect a system phone and a standard device or two standard devices together using the 267F2 bridging adapter.

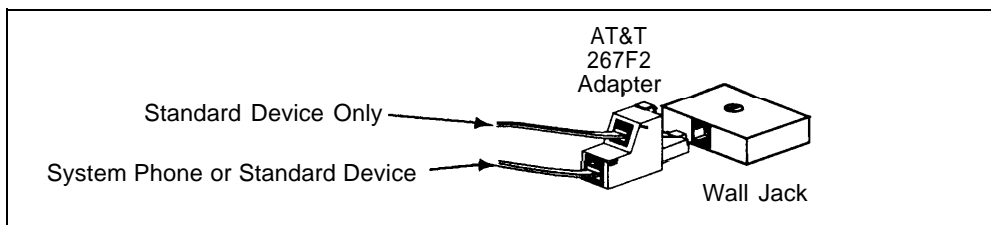

Figure 3. Combination Extension Using Bridging Adapter

Installation Procedures

Before installing the system, be sure you read the safety instructions on page ii.



WARNING:

There are no customer-serviceable components inside the system modules or backplane. There are hazardous voltages within that can cause severe or fatal personal injury. DO NOT OPEN THE MODULES.

Installing the Control Unit and Modules

Install the control unit's backplane within five feet (1.5 meters) of a properly grounded AC electrical outlet (not controlled by a switch) and the network interface jacks. In addition, when you mount the backplane on the wall, leave at least six inches (2.34 cm) of clearance at the top and sides, and two feet (0.6 meters) at the front and bottom to ensure proper ventilation.

- 1
 - A) Hold the backplane against the wall.
 - B) Using the four screw keyholes in the backplane as a template, mark screw locations on the wall.
 - C) Start four #12 screws, leaving the screw heads approximately 1/4" away from the wall.
 - D) Slip the backplane onto the screws and tighten them.
- 2
 - A) Slide the processor module into the center slot of the control unit—pressing the locking tab on the bottom of the slot as you push in the module will make insertion easier.
 - B) Push slowly but firmly until the module locks into place with two snaps, and is attached to the rear of the backplane and held in place by the locking tab. Do not force the module. If it does not insert easily, remove the module, clear any obstruction, and reinsert.
- 3
 - A) Slide the first 206 module into the *leftmost* slot of the backplane. (The system will not work if a 206 module is not installed in this slot.)
 - B) Going from left to right, install 206 modules first, then any 400 (or 200) modules. The 400 modules *should always* be to the right of all 206 modules, so the extensions will be numbered consecutively. Hold down the locking tab and align the dovetail guides on the sides of the module with the guides on any previously inserted modules.

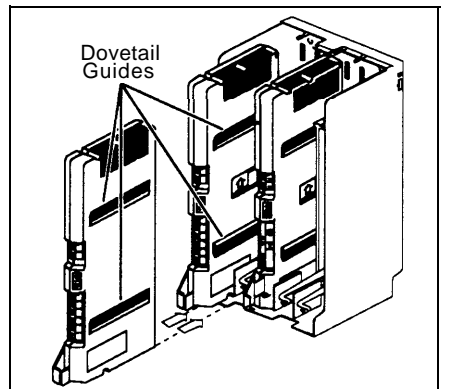
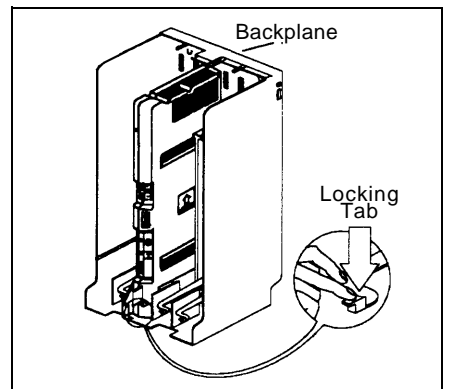
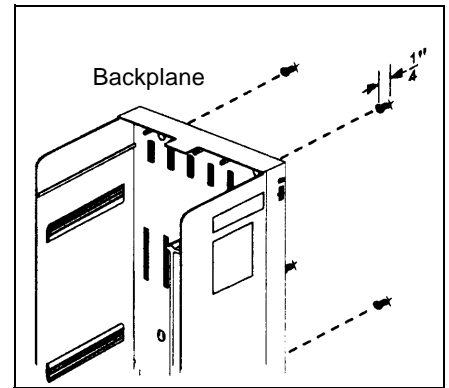

- 4**
- A) To power down the control unit, pull out the main circuit breaker on the control unit.
On a PARTNER Plus 220V system, move the on/off switch to the “off” position (“O”).
 - B) Press the AC power cord firmly into the power jack on the top right side of the backplane until it locks into place.
 - C) Plug the other end of the power cord into a properly grounded three-prong wall outlet not controlled by a switch.
 - D) To power up the control unit, push in the main circuit breaker.
On a PARTNER Plus 220V system, move the on/off switch to the “on” position (“I”).

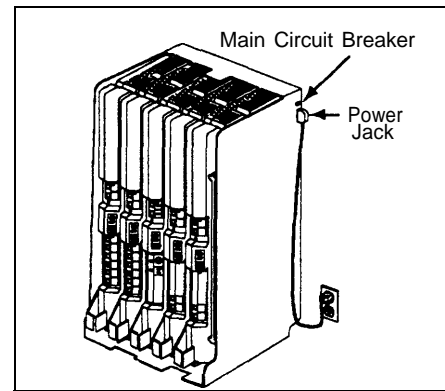

- 5** Check all green lights on the fronts of the modules. If all the lights are lit, you can go to the next section; otherwise:
- A) *If a single light is out*, power down the control unit, reseal the module, then power up the control unit.
If multiple lights are out, power down the control unit, reseal the first leftmost module that has a light out, then power up the control unit.
 - B) *If the lights are still out*, call the appropriate support telephone number as instructed on the inside front cover.

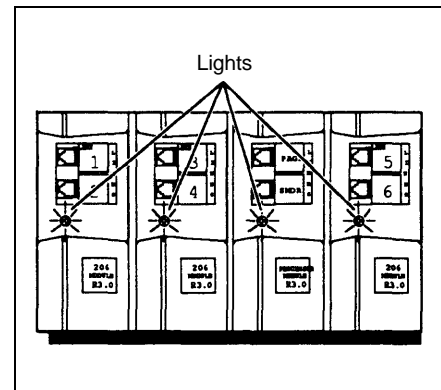

Connecting Lines and Extensions

If extensions are not wired to any modular jacks, call a qualified service technician.

- 1**
 - A) Test for dial tone at the network interface jacks before connecting outside lines to the control unit. For the test, connect a standard phone to the first network interface jack.
 - B) Lift the handset and listen for dial tone. (If there is no dial tone, contact your local telephone company before continuing.)
 - C) Repeat for each network interface jack.
- 2**
 - A) Connect line cords to the line jacks on 206 and 400 modules, starting with the top line jack on the leftmost 206 module.
 - B) Route each cord through the hook on the front of the module, and then push the cords through the space below the module and out through the back.
 - C) Pull the cords from behind the backplane, leaving at least two feet of slack in the cords (for future maintenance so you can easily reconnect cords after replacing system modules).
- 3** Connect the free end of each line cord to the appropriate network interface jack.
- 4**
 - A) Test the lines—plug a system phone into extension 10. Press the line buttons for each outside line and listen for dial tone.
 - B) Repeat for extensions 16, 22, and 28 (if available).

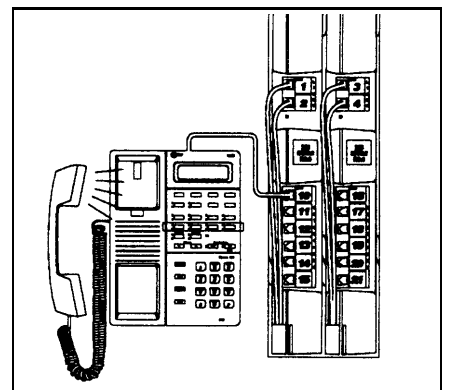
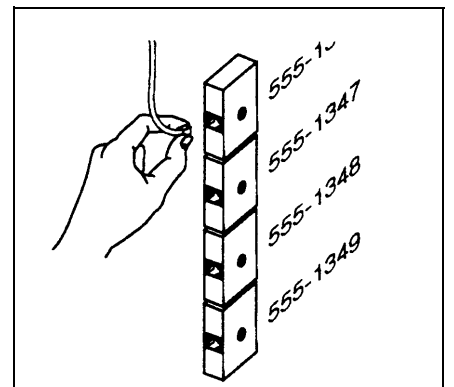
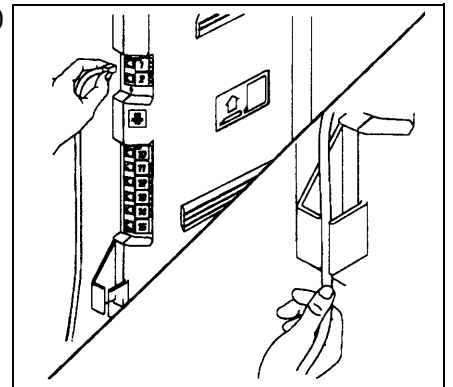
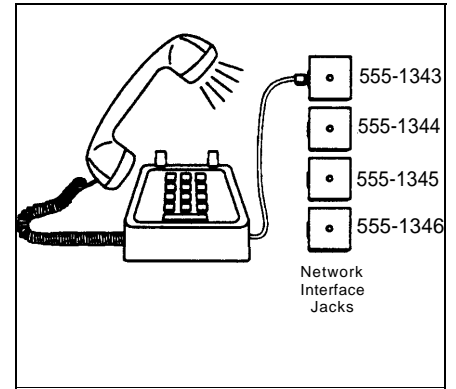

- 5**
- A) Connect modular telephone cords to 206 module extension jacks, starting at the top extension jack on the leftmost module.
 - B) Route each cord through the hook on the front of the module, and then push the cords through the space below the module and out through the back.
 - C) Pull the cords from behind the backplane, leaving at least two feet of slack to allow easy replacement of system modules (for future maintenance so you can easily reconnect cords after replacing system modules).
 - D) Connect the free end of each modular telephone cord to the modular connecting blocks for system extensions.

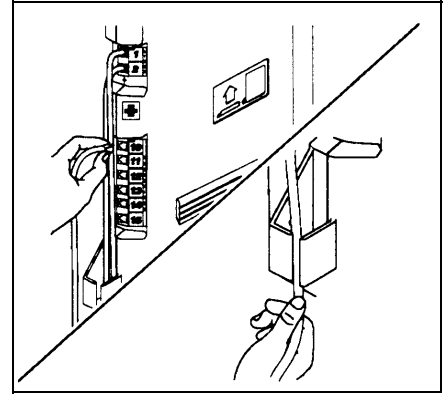

- 6**
- A) Place the cover on the control unit—this is especially important to keep the modules dust-free and the system working efficiently. To cover the control unit, while holding the cover at an angle, gently move the top rear edge of the cover over the top of the control unit.
 - B) Match up the grooves where the top edge of the cover meets the backplane, and gently push the edge into place.
 - C) Lower the bottom of the cover until it is secured in place.

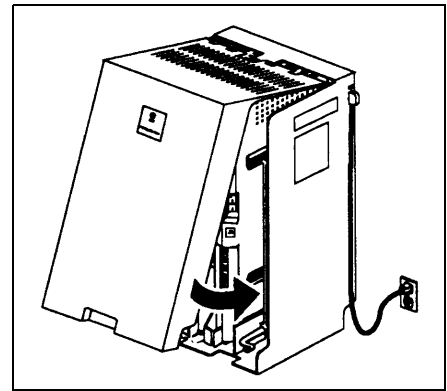

Connecting Caller ID Display Units

To get Caller ID information for an extension, you must first subscribe to the service (on a per-line basis) from your local telephone company, then connect the units as described here. You must connect the Caller ID display unit directly to the line that supports Caller ID at the network interface jack. Additionally, you must provide a separate wiring run for the unit to the appropriate location. To have additional wiring runs installed, call a qualified service technician.

NOTE:

To have Caller ID for multiple lines at a single phone, you must provide a separate box and a separate wiring run for each line.

- 1** Insert an AT&T 267F2 bridging adapter into the network interface jack associated with the line that has Caller ID service.
- 2**
 - A) Plug one end of a line cord into a jack on the bridging adapter.
 - B) Plug the free end of the line cord into the appropriate line jack in the control unit.
 - C) Route the cord as you did for other line and extension cords.
- 3**
 - A) Plug one end of a second line cord into the other jack on the bridging adapter.
 - B) Plug the free end of the cord into the appropriate modular connecting block in the equipment room.
 - C) Plug the Caller ID display unit into the additional modular jack—provided by the separate wiring run—at the appropriate location.
 - D) Place the Caller ID display unit next to the phone.
 - E) Make sure the Caller ID line is assigned to the extension where the Caller ID display unit is located. Refer to “Line Assignment” in Chapter 5 of the *PARTNER Plus Communications System Programming and Use* guide for programming instructions.

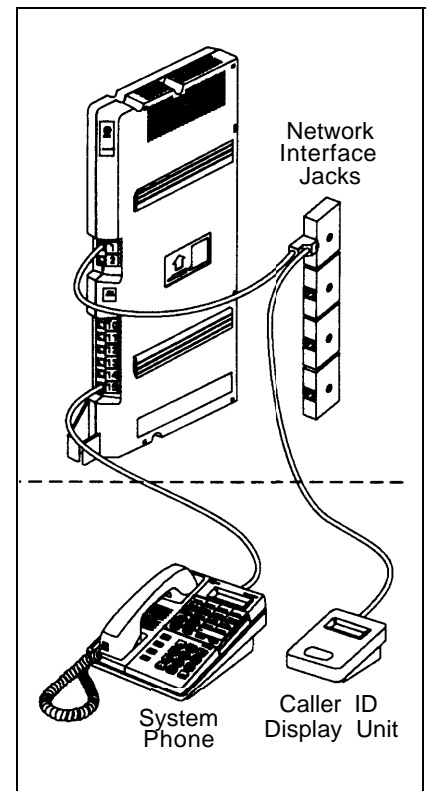

Assembling System Phones

You can either desk mount or wall mount a system phone. If the system phone is manufactured with a *separate* stand, you can use the stand to either wall mount the phone or raise the angle of the phone when desk mounting. (The stand is *required* for MLS-34D phones.) Alternatively, some system phones—such as the MLS-18D—are manufactured with a *fixed* stand. Any instructions below for installing the stand do not apply to this type of phone. (Wall mounting is not recommended for display phones.)

Desk Mounting

- 1**
 - A) Plug one end of the handset cord into the jack on the handset and the other end into the small jack on the left side of the base. For an MLS-34D phone, go directly to Step 2.
 - B) Plug one end of the phone cord into the jack on the bottom of the phone. If the phone has multiple jacks, plug the cord into the “LINE” jack.
 - C) Push the cord into place along the channel on the bottom of the phone.
 - D) If you want to raise the angle of the phone, go to Step 2; if not—or if you have a phone with a fixed stand—go to Step 3.
- 2**
 - A) To install the telephone stand (required for the MLS-34D), gently place the phone upside down, with the low end of the phone to your right.
 - B) Insert the tab on the narrow end of the stand into the right slot on the bottom of the phone. (For an MLS-34D phone, feed the cord through the hole in the center of the stand and plug it in.)
 - C) Insert the other tab into the left slot, pushing the stand down and slightly inward until the tab locks into place.
- 3**
 - A) Turn the phone over so it is right side up.
 - B) Remove the plastic cover from the phone. Label the button sheet to show any programmed lines or button features, then place it on the phone so the holes on the sheet fit over the buttons. Carefully replace the plastic cover.
 - C) Slide the *Quick Reference* card under the telephone.

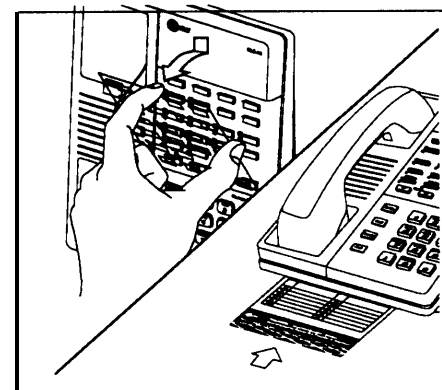
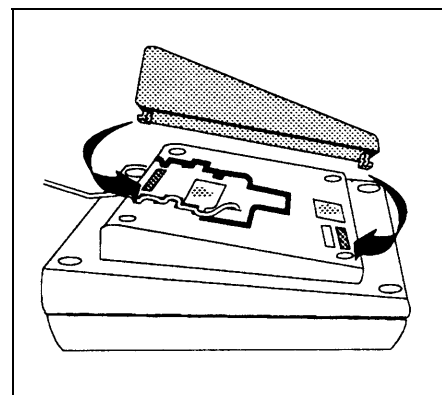
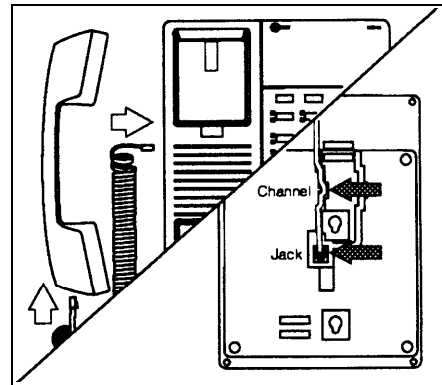

Wall Mounting

If you wall mount a display phone, the display may be difficult to read, so desk mounting is recommended. (Wall mounting instructions apply to *corded* MLS-model phones only. To wall mount an MLC-6 cordless phone, follow the instructions in the booklet provided with the phone.)

Wall Mounting Phones with Separate Stands

- 1** Reverse the plastic hook that sits in the earpiece part of the handset cradle.
- 2**
 - A) To install the telephone stand, gently place the phone upside down with the low end of the phone to your right.
 - B) Insert the tab on the narrow end of the stand into the left slot on the base of the phone. (For an MLS-34D phone, feed the cord through the hole in the center of the stand and plug it in.)
 - C) Insert the other tab into the right slot, pushing the stand down and slightly inward until the tab locks into place.
- 3**
 - A) Insert the phone cord through the center of the stand and plug it into the jack on the base of the phone, then plug the other end into the modular wall jack.
 - B) Mount the phone on the wall plate using the screw keyholes on the base of the stand. For proper mounting, the wall plate must be an AT&T 630B connecting block.
 - C) Connect the handset cord as described in "Desk Mounting," Step 1A, and label the button sheet as in Steps 3A and 3B.

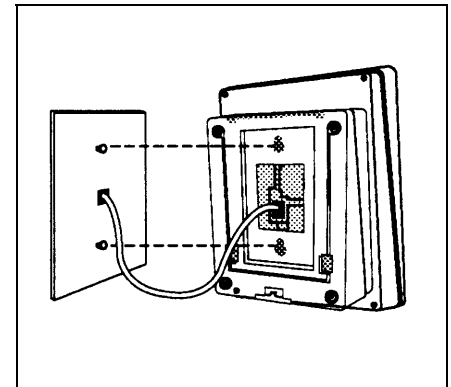
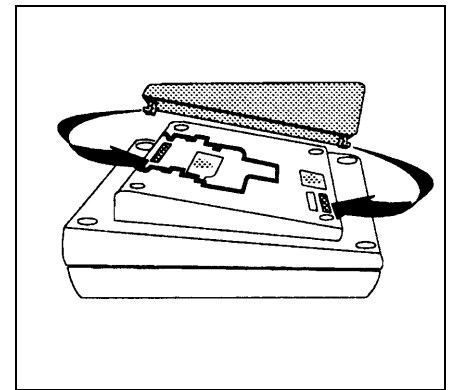
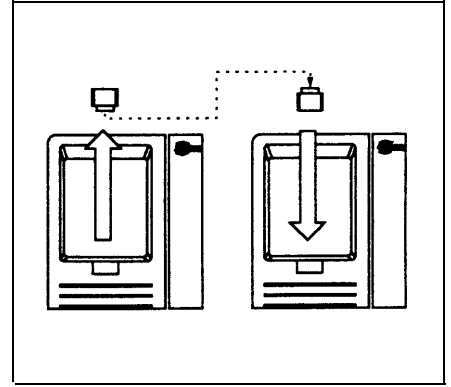

Wall Mounting Phones with Fixed Stands

Make sure the telephone cord is unplugged from the bottom of the phone before proceeding.

- 1**
 - A) Reverse the plastic hook that sits in the earpiece part of the handset cradle.
 - B) Gently place the phone upside down.

- 2** A) Unscrew the phone's four mounting screws and lift the base of the phone off the top.



CAUTION:

Do not touch electrical circuitry. To do so will expose you to a risk of electrical shock and possibly damage the equipment.

- B) Turn the base of the phone upside down so that the phone base can be mounted parallel to the wall—and then place it back on the base.
- C) Replace the four mounting screws.

- 3** A) Insert the phone cord through the center of the stand and plug it into the jack labeled "AUX" on the bottom of the phone. Plug the other end into the modular wall jack.
- B) Mount the phone on the wall plate using the screw keyholes on the base of the stand. For proper mounting, the wall plate must be an AT&T 630B connecting block.
- C) Connect the handset cord as described in "Desk Mounting," Step 1A, and label the button sheet as in Steps 3A and 3B.

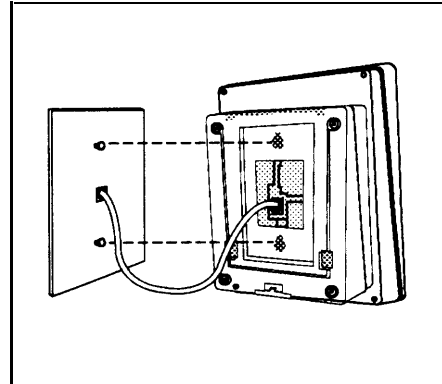
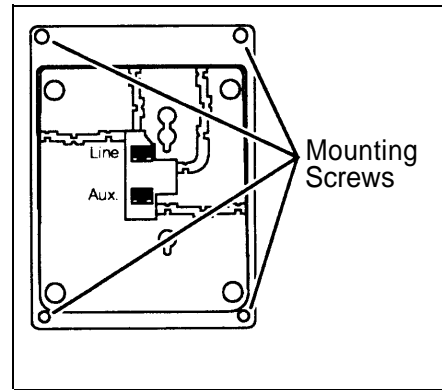

Connecting and Testing Telephones

- 1** To connect a phone, plug the modular telephone mounting cord into a modular wall jack or directly into a 206 module extension jack. (If you are connecting a standard phone and its mounting cord is loose, try an AT&T D2R mounting cord instead.)

To install two phones (or other devices) on a single extension jack, see "Combination Extensions" earlier in this guide

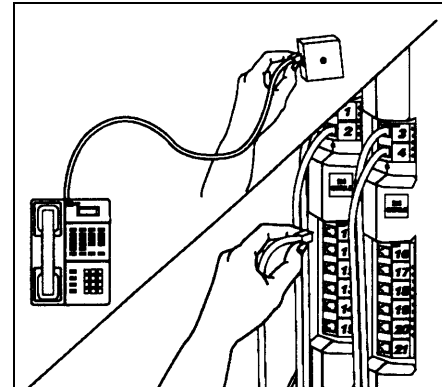

- 2** A) Test the telephone for proper operation—to test the power and lights on a system phone, press and hold the [#] button for five seconds.
- B) Before releasing the [#] button, lift the handset. All lights should light, the ringer should sound, and (on the MLS-34D, MLS-18D, or MLS-12D phones only) a test pattern should appear on the display. (If not, call the appropriate support telephone number as instructed on the inside front cover.)
- C) Replace the handset; the phone is now in normal operating mode.

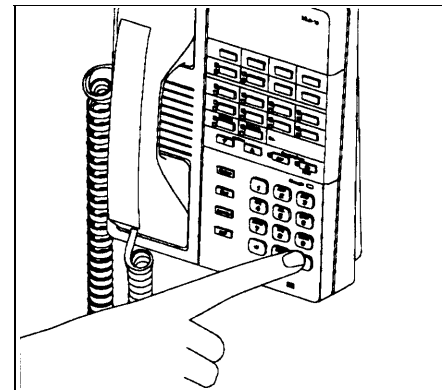

Connecting Paging, Music-On-Hold, and Call Reporting (SMDR) Devices

Only steps for connection to the processor module are provided here. Refer to Chapter 4 of the *PARTNER Plus Programming and Use* guide and the manufacturer's instructions for additional information on installing, programming, and using these devices.

Paging System

- 1** Insert the modular plug into the PAGE jack on the processor module.
- 2** Route the cord as you did for line and extension cords, then connect it to the paging system.

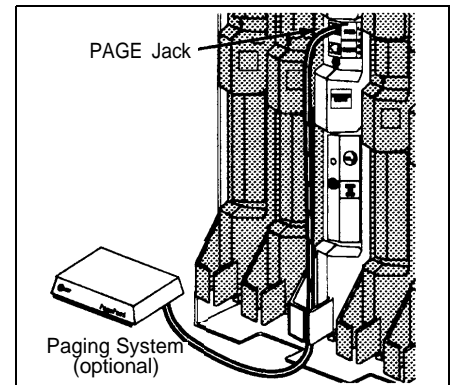

Music-on-Hold Audio Source

If you use equipment that rebroadcasts music or other copyrighted materials, you may be required to obtain a license from a third party such as ASCAP or BMI. Or you can purchase a Magic On Hold system from AT&T, which does not require you to obtain such a license.

- 1**
 - A) Insert an RCA phono plug into the MUSIC ON HOLD jack on the processor module.
 - B) Route the cord as you did for line and extension cords, and then connect it to the audio source.
- 2**
 - A) First set the unit's volume to the lowest setting. Use a flathead screwdriver to turn the volume control on the processor module counterclockwise until it stops.
 - B) Place a call on hold and listen while adjusting the volume, clockwise. If you do not hear music at any setting, check "Music On Hold (#602)" in Chapter 5 of the *PARTNER Plus Communications System Programming and Use* guide.

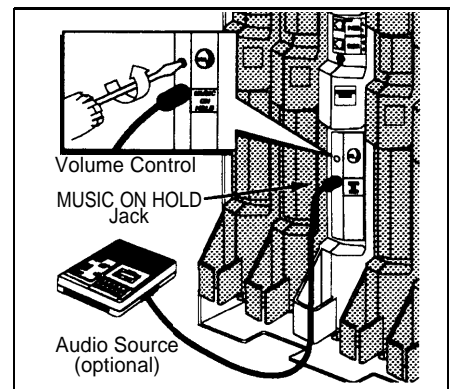

Call Reporting (SMDR) Printer

- 1** Insert one end of a D8W modular cord into the SMDR jack on the processor module.
- 2** Plug the other end into an AT&T 355A adapter and then plug the 355A adapter into the RS-232C serial port on the printer.

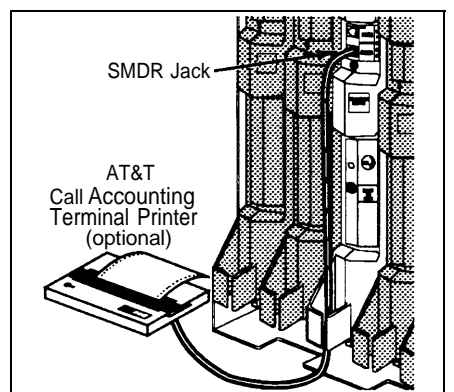

Connecting Intercom Autodialers

Since the autodialer has a fixed stand, you may need to adjust the height of the system phone—by installing a stand—to match the height of the autodialer. Refer to Step 2 of “Desk Mounting” under “Assembling System Phones” for instructions.

You can wall mount an Intercom Autodialer to work next to a wall-mounted system phone; however, wall-mounting system display phones is not recommended.

- 1**
 - A) Unplug the phone's modular telephone cord from the jack on the bottom of the phone and the wall jack, and save the cord for Step 1D.
 - B) Plug one end of the D8W cord, supplied with the autodialer, into the jack on the bottom of the phone. (If the phone has multiple jacks, plug the cord into the “LINE” jack.)
 - C) Route the other end through the groove at the back of the autodialer and plug it into the OUT jack.
 - D) Route one end of the modular telephone cord through the groove at the back of the autodialer and plug it into the IN jack; plug the other end into the wall jack for extension 10 or 11.

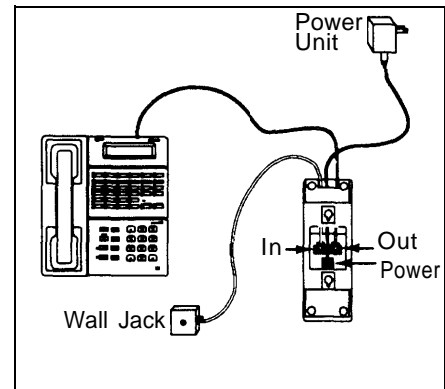

- 2**
 - A) Connect the keyed power cord, supplied with the autodialer, to the POWER jack on the bottom of the autodialer, routing it through the groove as you did in Step 1.
 - B) If the keyed power cord is not attached to the power supply unit, plug the free end of the cord into the modular jack on the power supply unit; otherwise, go to Step 2C.
 - C) Plug the power unit into the electrical outlet.



CAUTION:

Use only the power unit supplied by AT&T for the Intercom Autodialer.

- 3**
 - A) Arrange the autodialer on your desk next to the phone.
 - B) Remove the plastic cover from each autodialer and label the button sheet with employee names. Place the button sheet back on the autodialer, and then carefully replace the plastic cover.

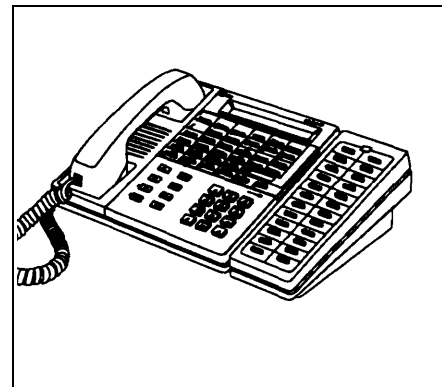

Equipment Upgrades

Adding New Modules

- 1**
 - A) To power down the control unit, pull out the main circuit breaker.

On a PARTNER Plus 220V system, move the on/off switch to the “off” position (“O”).
 - B) To remove the cover, place one hand on the handle on the bottom front of the cover and place your other hand on the top of the cover.
 - C) Gently pull the cover up from the bottom and tilt it towards the top until it detaches from the backplane.
- 2**
 - A) Before you insert the new module, make sure that all 400 (or 200) modules are installed to the right of all 206 modules. Also, remember to hold down the locking tab and to align the dovetail guides on the sides of the modules as you insert the new module.
 - B) Push the module slowly but firmly until it locks into place with two snaps, and is attached to the rear of the backplane and held in place by the locking tab on the bottom of the slot. Do not force the module. If it does not insert easily, remove the module, clear any obstruction, and reinsert.
- 3**
 - A) See “Connecting Lines and Extensions” for instructions on connecting line and/or extension jack cords to the new module.
 - B) To power up the control unit, push in the main circuit breaker.

On a PARTNER Plus 220V system, move the on/off switch to the “on” position (“I”).
- 4** Check all green lights on the fronts of the modules. If all the lights are lit, installation is complete; otherwise:
 - A) *If a single light is out*, power down the control unit, reseat the module, then power up the control unit.

If multiple lights are out, power down the control unit, reseat the first leftmost module that has a light out, then power up the control unit.
 - B) *If the lights are still out*, call the appropriate support telephone number as instructed on the inside front cover.

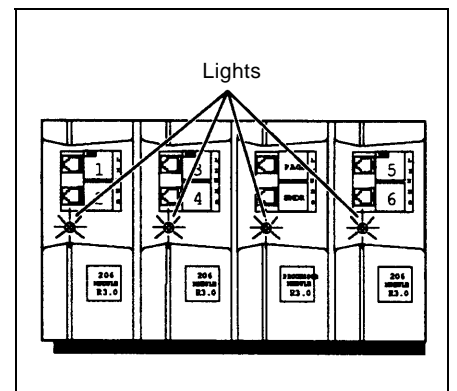
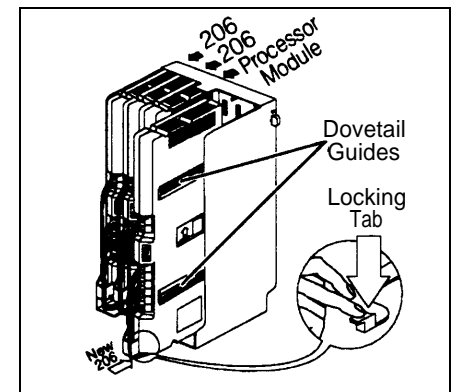
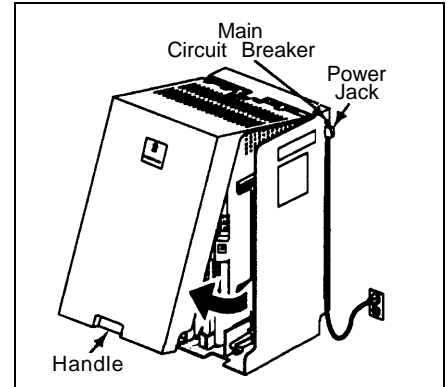

- 5**
- A) To replace the cover, while holding the cover at an angle, gently move the top rear edge of the cover over the top of the control unit and match up the grooves where the top edge of the cover meets the backplane. Gently push the edge into place.
 - B) Lower the bottom of the cover until it is secured in place.

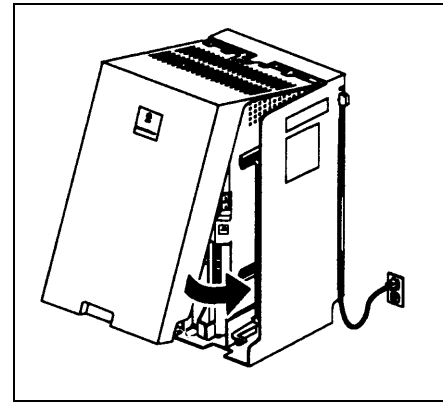

Replacing System Modules

- 1**
- A) To power down the control unit, pull out the main circuit breaker.
On a PARTNER Plus 220V system, move the on/off switch to the "off" position ("O").
 - B) To remove the cover, place one hand on the handle on the bottom front of the cover and place your other hand on the top of the cover.
 - C) Gently pull the cover up from the bottom and tilt it towards the top until it detaches from the backplane.

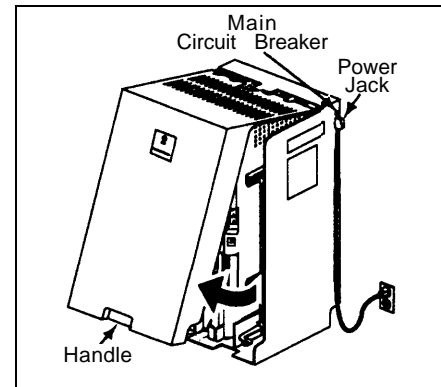

- 2**
- A) Check the slack in the wires. If there is not enough slack to remove the module without pulling the line and extension cords free, label and disconnect the wires before continuing with Step 2B.
 - B) Place one hand on top of the module. With your other hand, grip the plastic bracket on the bottom front of the module, and use your middle finger to hold down the locking tab just below the bracket. Pull out the old module.
 - C) To insert the replacement, hold down the locking tab and align the dovetail guides on the sides of the modules. Push slowly but firmly until the module locks into place with two snaps, and is attached to the rear of the backplane and held in place by the locking tab. Do not force the module. If it does not insert easily, remove the module, clear any obstruction, and reinsert.

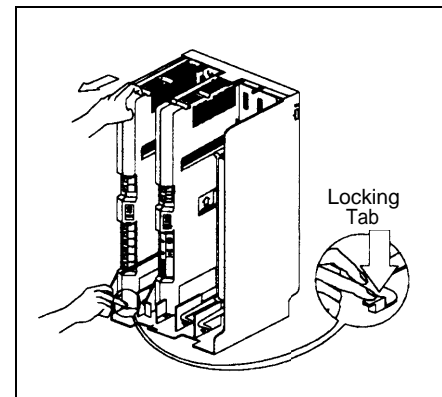

- 3**
- A) Connect the line and extension cords one at a time, making sure to place the correct cords into their corresponding jacks on the new module.
 - B) To power up the control unit, push in the main circuit breaker.

On a PARTNER Plus 220V system, move the on/off switch to the "on" position ("I").

- 4** Check all green lights on the fronts of the modules. If all the lights are lit, installation is complete; otherwise:

- A) *If a single light is out*, power down the control unit, reseal the module, then power up the control unit.

If multiple lights are out, power down the control unit, reseal the first leftmost module that has a light out, then power up the control unit.

- B) *If the lights are still out*, call the appropriate support telephone number as instructed on the inside front cover.

- 5**
- A) To replace the cover, while holding the cover at an angle, gently move the top rear edge of the cover over the top of the control unit and match up the grooves where the top edge of the cover meets the backplane. Gently push the edge into place.
 - B) Lower the bottom of the cover until it is secured in place.

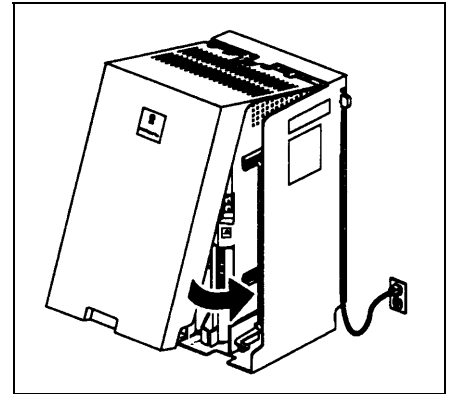
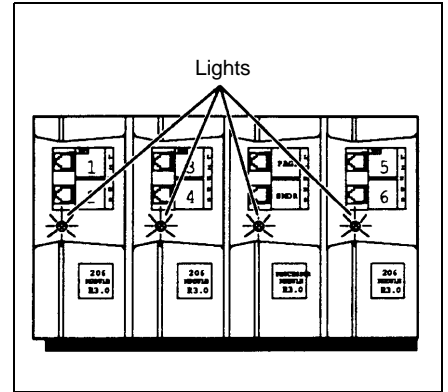

Specifications

Capacities	System <ul style="list-style-type: none"> ■ 12 outside lines via line jacks on two 206 plus two 400 modules ■ 24 extensions via extension jacks on four 206 modules ■ 1 loudspeaker paging system via PAGE jack on processor module ■ 1 audio source via MUSIC ON HOLD jack on processor module (RCA phono plug required) ■ 1 call reporting device via SMDR jack on processor module (355A/F adapter required) ■ 2 doorphones via 2 ext. jacks 	206 Module <ul style="list-style-type: none"> ■ 2 outside lines ■ 6 extensions 400 Module <ul style="list-style-type: none"> 4 outside lines 	Extension Jack <ul style="list-style-type: none"> ■ Maximum 2 devices per extension jack, total REN on jack not to exceed 2.0* (System phone REN: 0.0 (zero)) ■ No more than one system phone per jack <p><i>For programming, a system display phone must be connected to extension 10 or 11.</i></p>																																	
Dimensions and Weights (approx.)	<table border="0"> <tr> <td>■ Processor Module</td> <td>11"(D) x 17"(H) x 1.5"(W) or 27.9 x 43.2 x 3.8 cm</td> <td>4.0 lbs or 1.8 kgs</td> </tr> <tr> <td>■ 206 module</td> <td>11"(D) x 17"(H) x 1.5"(W) or 27.9 x 43.2 x 3.8 cm</td> <td>4.5 lbs or 2.0 kgs</td> </tr> <tr> <td>■ 400 module</td> <td>11"(D) x 17"(H) x 1.5"(W) or 27.9 x 43.2 x 3.8 cm</td> <td>4.0 lbs or 1.8 kgs</td> </tr> <tr> <td>■ Backplane & cover</td> <td>12"(D) x 19"(H) x 11"(W) or 30.5 x 48.3 x 27.9 cm</td> <td>5.5 lbs or 2.5 kgs</td> </tr> <tr> <td>■ MLS-34D phone</td> <td>9.7"(D) x 5.3"(H) x 10"(W) or 24.6 x 13.5 x 25.4 cm</td> <td>3.1 lbs or 1.4 kgs</td> </tr> <tr> <td>■ MLS-18D phone</td> <td>9.5"(D) x 5"(H) x 6.75"(W) or 24.1 x 12.7 x 17.1 cm</td> <td>2.8 lbs or 1.3 kgs</td> </tr> <tr> <td>■ MLS-12D phone</td> <td>9.5"(D) x 5"(H) x 6.75"(W) or 24.1 x 12.7 x 17.1 cm</td> <td>2.8 lbs or 1.3 kgs</td> </tr> <tr> <td>■ MLS-12 phone</td> <td>9.5"(D) x 5"(H) x 6.75"(W) or 24.1 x 12.7 x 17.1 cm</td> <td>2.7 lbs or 1.2 kgs</td> </tr> <tr> <td>■ MLS-6 phone</td> <td>9.5"(D) x 5"(H) x 6.75"(W) or 24.1 x 12.7 x 17.1 cm</td> <td>2.7 lbs or 1.2 kgs</td> </tr> <tr> <td>■ MLC-6 phone</td> <td>9.4"(D) x 3.4"(H) x 7"(W) or 23.9 x 8.6 x 17.8 cm</td> <td>2.8 lbs or 1.3 kgs</td> </tr> <tr> <td>■ MLS-CA24 Autodialer</td> <td>9.7"(D) x 5.3"(H) x 3.4"(W) or 24.6 x 13.5 x 8.6 cm</td> <td>1.3 lbs or 0.6 kgs</td> </tr> </table>	■ Processor Module	11"(D) x 17"(H) x 1.5"(W) or 27.9 x 43.2 x 3.8 cm	4.0 lbs or 1.8 kgs	■ 206 module	11"(D) x 17"(H) x 1.5"(W) or 27.9 x 43.2 x 3.8 cm	4.5 lbs or 2.0 kgs	■ 400 module	11"(D) x 17"(H) x 1.5"(W) or 27.9 x 43.2 x 3.8 cm	4.0 lbs or 1.8 kgs	■ Backplane & cover	12"(D) x 19"(H) x 11"(W) or 30.5 x 48.3 x 27.9 cm	5.5 lbs or 2.5 kgs	■ MLS-34D phone	9.7"(D) x 5.3"(H) x 10"(W) or 24.6 x 13.5 x 25.4 cm	3.1 lbs or 1.4 kgs	■ MLS-18D phone	9.5"(D) x 5"(H) x 6.75"(W) or 24.1 x 12.7 x 17.1 cm	2.8 lbs or 1.3 kgs	■ MLS-12D phone	9.5"(D) x 5"(H) x 6.75"(W) or 24.1 x 12.7 x 17.1 cm	2.8 lbs or 1.3 kgs	■ MLS-12 phone	9.5"(D) x 5"(H) x 6.75"(W) or 24.1 x 12.7 x 17.1 cm	2.7 lbs or 1.2 kgs	■ MLS-6 phone	9.5"(D) x 5"(H) x 6.75"(W) or 24.1 x 12.7 x 17.1 cm	2.7 lbs or 1.2 kgs	■ MLC-6 phone	9.4"(D) x 3.4"(H) x 7"(W) or 23.9 x 8.6 x 17.8 cm	2.8 lbs or 1.3 kgs	■ MLS-CA24 Autodialer	9.7"(D) x 5.3"(H) x 3.4"(W) or 24.6 x 13.5 x 8.6 cm	1.3 lbs or 0.6 kgs	Switch Fabric	<ul style="list-style-type: none"> ■ Full digital, nonblocking
■ Processor Module	11"(D) x 17"(H) x 1.5"(W) or 27.9 x 43.2 x 3.8 cm	4.0 lbs or 1.8 kgs																																		
■ 206 module	11"(D) x 17"(H) x 1.5"(W) or 27.9 x 43.2 x 3.8 cm	4.5 lbs or 2.0 kgs																																		
■ 400 module	11"(D) x 17"(H) x 1.5"(W) or 27.9 x 43.2 x 3.8 cm	4.0 lbs or 1.8 kgs																																		
■ Backplane & cover	12"(D) x 19"(H) x 11"(W) or 30.5 x 48.3 x 27.9 cm	5.5 lbs or 2.5 kgs																																		
■ MLS-34D phone	9.7"(D) x 5.3"(H) x 10"(W) or 24.6 x 13.5 x 25.4 cm	3.1 lbs or 1.4 kgs																																		
■ MLS-18D phone	9.5"(D) x 5"(H) x 6.75"(W) or 24.1 x 12.7 x 17.1 cm	2.8 lbs or 1.3 kgs																																		
■ MLS-12D phone	9.5"(D) x 5"(H) x 6.75"(W) or 24.1 x 12.7 x 17.1 cm	2.8 lbs or 1.3 kgs																																		
■ MLS-12 phone	9.5"(D) x 5"(H) x 6.75"(W) or 24.1 x 12.7 x 17.1 cm	2.7 lbs or 1.2 kgs																																		
■ MLS-6 phone	9.5"(D) x 5"(H) x 6.75"(W) or 24.1 x 12.7 x 17.1 cm	2.7 lbs or 1.2 kgs																																		
■ MLC-6 phone	9.4"(D) x 3.4"(H) x 7"(W) or 23.9 x 8.6 x 17.8 cm	2.8 lbs or 1.3 kgs																																		
■ MLS-CA24 Autodialer	9.7"(D) x 5.3"(H) x 3.4"(W) or 24.6 x 13.5 x 8.6 cm	1.3 lbs or 0.6 kgs																																		
Electrical Specifications	<ul style="list-style-type: none"> ■ 10 Watts (35 BTUs/hour) per 400 module, normal and maximum power consumption ■ 65 Watts (225 BTUs/hour) per 206 module during normal operation ■ 100 Watts (350 BTUs/hour) per 206 module during maximum power consumption ■ 4 Amps maximum current at full system capacity (processor module and four 206 modules) On a PARTNER Plus 220V System: 2.2 Amps maximum current ■ 4-day memory backup (96 hours) 	Processor Module Specifications	<ul style="list-style-type: none"> ■ 68000 microprocessor, 64K RAM, 256K ROM 																																	
Extension Jack Specifications	<ul style="list-style-type: none"> ■ Ringing voltage: +5VDC, -140 VDC peak to peak; trapezoidal wave shaping On a PARTNER Plus 220V System: +5VDC, -150 VDC peak to peak ■ 35- to 38-Volt talk battery ■ Ringing frequency: 20 Hz 	PAGE Jack Specifications	<ul style="list-style-type: none"> ■ Draws current on inner wire pair ■ Provides contact closure on outer wire pair ■ 600 Ohm impedance 																																	

* The two devices combined on an extension jack can be a system phone with a standard device, or two standard devices; DO NOT connect two system phones to the same extension jack. If a device lists two RENs, use the higher number when adding up RENs.

SMDR Output Format	<ul style="list-style-type: none"> ▪ 1200 baud ▪ No parity ▪ 8 data bits ▪ 2 stop bits
Environmental Requirements—Control Unit	<ul style="list-style-type: none"> ▪ Mount on a wall at least 2 feet (0.6 meters) from the floor (wall mounting required) ▪ Locate within 5 feet (1.5 meters) of the network interface jacks and an electrical outlet not controlled by a switch, using supplied 7-foot (2.1-meter) cords ▪ Operating temperature 32° to +104°F (0° to +40°C), not in direct sunlight ▪ Humidity 15%–90%, noncondensing ▪ For proper ventilation and easy replacement of modules, provide at least 6" (2.34cm) clearance at the top and sides and 2 feet (0.6 meters) at the front and bottom of the control unit. ▪ Locate in an area free of excess moisture, corrosive gases, dust, and chemicals
Electrical Requirements	<ul style="list-style-type: none"> ▪ 90–130 VAC, 50–60 Hz, 3-prong outlet separate ground, separately fused at 15 Amps On a PARTNER Plus 220V System: 180–264 VAC, fused at 10 Amps ▪ Outlet must not be controlled by an on/off switch ▪ Grounding to comply with Underwriters Laboratories (UL) 1459: <ul style="list-style-type: none"> A. An insulated grounding conductor that is not smaller in size and equivalent in insulation material and thickness to the grounded and ungrounded branch circuit supply conductors, except that it is green with or without one or more yellow stripes, is to be installed as part of the circuit that supplies the product or system. B. The grounding conductor mentioned in item A is to be connected to ground at the service equipment. C. The attachment-plug receptacles in the vicinity of the product or system are all to be of a grounding type, and the grounding conductors serving these receptacles are to be connected to earth ground at the service equipment.
Requirements for Out-of-Building Extensions	<p>Installation of a telephone or other standard (tip/ring) device in another building requires the following In-Range Out-of-Building (IROB) protectors to protect the control unit and device from electrical surges:</p> <ul style="list-style-type: none"> ▪ MLS-model telephone: two AT&T IROB protectors ▪ Standard device: one AT&T IROB protector plus one carbon block protector
Wiring	<ul style="list-style-type: none"> ▪ MLS-model phones: AT&T SYSTIMAX™ or at least 2-pair (4-wire) star ("home run" not "loop") ▪ Other standard telecommunications equipment (single-line phones, fax machines, answering machines, etc.): 1-pair (2-wire) mounting cords (AT&T D2R mounting cords recommended) ▪ Bridging adapter: AT&T 267F2 ▪ Range: 1,000 feet (305 meters) for MLS phones; 3,000 feet (915 meters) for standard devices
Safety Requirements	<ul style="list-style-type: none"> ▪ U.S.: Meets UL 1459 Issue 2 ▪ Canada: Meets CSA C22.2, 225
Government Approvals and Local Phone Company Information	<ul style="list-style-type: none"> ▪ U.S.: <ul style="list-style-type: none"> FCC Part 68 FCC registration number (U.S.): AS5 USA-61630-KF-E FCC Part 15 Class A REN (outside line jack): 0.9A per line jack Jack type: RJ11C ▪ Canada: <ul style="list-style-type: none"> DOC CP01, Issue 7 DOC registration number (Canada): 230 3756 DOC CS03, Issues 6 & 7 Load Number = 7 Loop start lines

518-455-213
Issue 1

June 1992

Graphics © 1988

